

VIEW A-A

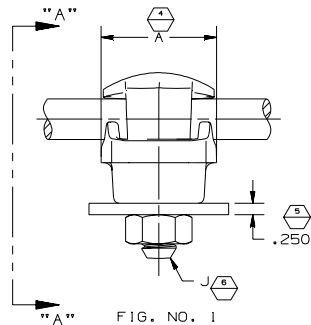

FIG. NO. 1

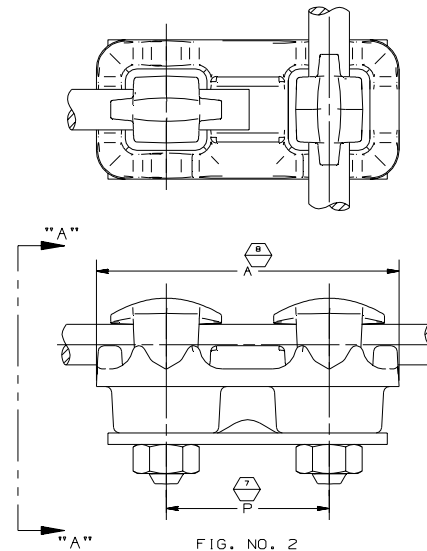

FIG. NO. 2

NOTE: * INDICATES TWO WAY TYPE CUPS AS SHOWN AT RIGHT.

NOTES:

- MAT'L: CUPS-255A BRONZE ALLOY.
EYEBOLTS-ALUMINUM BRONZE ALLOY.
NUTS & LOCKWASHERS - STAINLESS STEEL.
- FOR .75 PLATE, ADD "L" TO CAT. NO. AND ADD 0.5 INCHES TO THE "L" DIM. (EXAMPLE - TLS-62-L).
- FOR TIN PLATED BODY AND EYEBOLT ADD "TP" SUFFIX TO CAT. NO. (EXAMPLE - TLS-32-TP)
- FOR 2 NUTS AND 2 LOCKWASHERS ADD "2NW" SUFFIX TO CAT. NO. (EXAMPLE - TLS-22-L-2NW)
- FOR PARTS TO BE SUPPLIED WITH BELLEVILLE WASHERS ADD "BW" SUFFIX TO CAT. NO. (EXAMPLE: TLS-32-L-TP-BW)
- FOR PARTS WITH J = .500 ADD BW1 SUFFIX TO CAT. NO. TO OBTAIN SPECIAL BELLEVILLE WASHER (1.125X.531X.109)
- CLASSIFICATION OF DIMENSIONS AND REQUIREMENTS FOR INSPECTION:

CRITICAL--(XX/C) MAJOR--(XX/M) MINOR--(XX)

INSPECTION SYMBOL DRAWING

SYMBOLS USED : 1 - 8.

CATALOG NUMBER	FIG. NO.	CABLE RANGE		DIMENSIONS IN INCHES						
		MIN.	MAX.	A	B	L	R	J	P	
TLS-12	1	#10	#2	1.063	.875	1.813	.313	.375	-	
TLS-22	1	#10	#1	1.125	.875	1.938	.344	.375	-	
TLS-32	1	#8	2/0	1.500	1.125	2.375	.438	.500	-	
TLS-35	1	#8	2/0	1.250	1.063	2.000	.438	.375	-	
TLS-42	1	#6	250 MCM	1.500	1.250	2.625	.625	.500	-	
TLS-52	1	#2	350 MCM	1.688	1.313	2.750	.703	.500	-	
TLS-62	1	1/0	500 MCM	1.688	1.563	3.063	.938	.500	-	
TLS-72	1	350 MCM	750 MCM	2.250	1.875	3.250	1.063	.500	-	
TLS-82	1	750 MCM	1000 MCM	2.250	2.063	3.375	1.250	.500	-	
TLS-86	1	2/0	1000 MCM	2.250	2.188	4.188	1.250	.500	-	
TLS-102	1	500 MCM	2000 MCM	2.250	3.000	4.750	1.719	.500	-	
TLD-12	*2	#10	#2	2.188	1.063	1.813	.313	.375	1.125	
TLD-22	*2	#10	#1	2.375	1.125	1.938	.344	.375	1.250	
TLD-32	*2	#8	2/0	3.250	1.500	2.375	.438	.500	1.750	
TLD-35	*2	#8	2/0	2.500	1.250	2.000	.438	.375	1.250	
TLD-52	2	#6 SOL	350 MCM	3.438	1.313	2.750	.703	.500	1.750	
TLD-62	2	1/0 SOL	500 MCM	3.438	1.563	3.063	.938	.500	1.750	
TLD-89	2	2/0 SOL	1000 MCM	3.438	1.75	3.563	1.250	.500	1.750	
TLD-92	2	1000 MCM	1500 MCM	4.000	2.500	4.000	1.500	.500	1.750	
TLD-102	2	500 MCM	2000 MCM	4.000	3.000	4.750	1.718	.500	1.750	
TLS-58	1	#2	350 MCM	1.875	1.438	3.000	.688	1.500	-	
TLS-62-LP	1	1/0	500 MCM	2.188	1.688	3.906	.938	.625	-	
TLS-32-L	1	#8	2/0	1.500	1.125	2.875	.438	.500	-	
TLS-35L	1	#8	#2/0	1.250	1.063	2.500	.438	.375	-	
TLS-92	1	1000 MCM	1500 MCM	2.250	2.313	4.000	1.500	.500	-	
TLD-58	2	#2	350 MCM	3.563	1.813	3.000	.813	.500	1.750	

EC #	REV	DESCRIPTION	DATE	CHG BY	APPR'd
63860	23	ADD NOTE 6 TO DRAWING	2/15/16	RK	WJI

REVISION HISTORY

THIRD ANGLE PROJECTION

HPS®	HUBBELL® POWER SYSTEMS
TITLE SINGLE & DOUBLE TAP LUGS FOR USE ON 1/4 - 3/4 PLATE TYPE TLS AND TLD	
SIZE DWG NO. C C-2618	CAT / PART / ASSY NO. SEE TABLE
SCALE: NTS	DRN BY: TS
DATE: 2-15-16	SHEET 1 OF 1

CONFIDENTIAL: THIS DRAWING AND ITS CONTENTS ARE CONFIDENTIAL AND THE EXCLUSIVE PROPERTY OF HUBBELL POWER SYSTEMS. NO PUBLICATION, DISTRIBUTION OR COPIES MAY BE MADE WITHOUT THE WRITTEN CONSENT OF HUBBELL POWER SYSTEMS. HUBBELL POWER SYSTEMS UNPUBLISHED ALL RIGHTS RESERVED UNDER THE COPYRIGHT LAWS.